



Features and Benefits

Ultra-high stability up to $\pm 5 \times 10^{-11}$ at -30°C to $+70^{\circ}\text{C}$
 Very low aging up to $\pm 1 \times 10^{-10}$ /day, 1.5×10^{-8} /year
 Low phase-noise level at -165 dBc/Hz, TYP floor
 Excellent Allan variance, 1s to 1×10^{-12}
 Small size packaging

Typical Applications

Rubidium Standard Replacement
 Stratum 2 Clock Systems
 Instrumentation
 GPS Receivers

Description

A contemporary series of ultra-stable double oven OCXO with the latest circuit topologies.

Mechanical Drawing & Pin Connections

Drawing No: MD140079-2

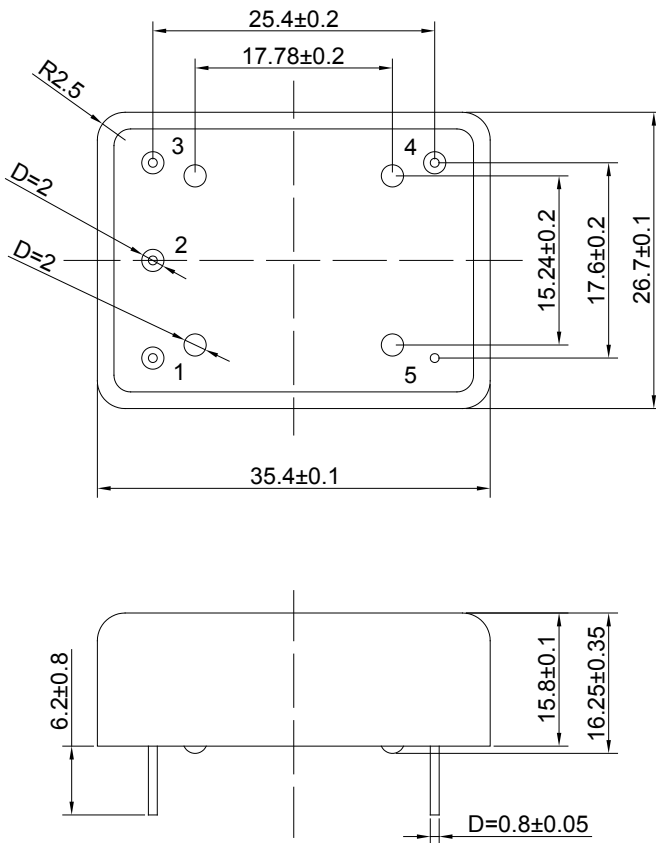

Pin	Signal
1	Electrical tuning
2	Reference voltage
3	+V Supply
4	RF OUT
5	GND

Unit : mm
 1mm=0.0394inch

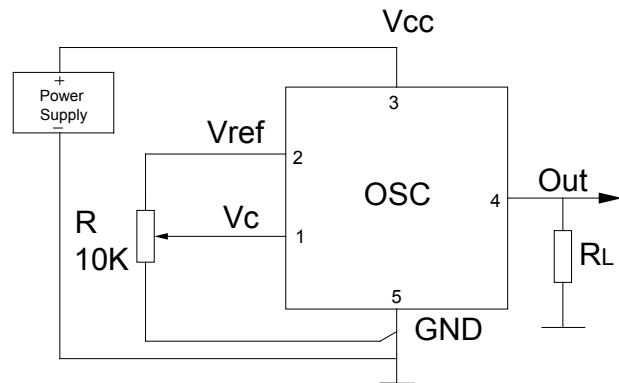

R - precision resistor with low TCR



Specifications

General Specifications							
Parameter	Sym	Condition	Value			Unit	Note
			Min.	Typ.	Max		
Frequency Range	F ₀		5		100	MHz	
RF Output							
HCMOS (TTL) option	Load		10		15	kOhm pF	For 10 MHz operational frequency
	H-level voltage	V _H	3.8			V	
	L-level voltage	V _L			0.4	V	
	Duty Cycle		45		55	%	
	Rise / Fall Time				10	ns	For 10 MHz operational frequency
Sine-wave option	Level	L	+6	+8	+10	dBm	
	Load	R _L		50		Ohm	
	Harmonics level				-30	dBc	
Sub-harmonics level		Operational frequency < 30 MHz Operational frequency ≥ 30 MHz		None -	-	dBc	Frequency multiplier is used
Frequency Control*							
Control Voltage Range	V _c	V _{cc} =5 or 12V V _{cc} =3.3V	0 0		4.2 2.8	V	Tuning slope - positive
Tuning Range			±0.3	±0.4		ppm	
Reference voltage	V _{ref}	V _{cc} =5 or 12V V _{cc} =3.3V	4.0 2.7	4.2 2.8	4.3 2.9	V	
Frequency Stability							
Vs. temperature		-40°C to +85°C, ref 25°C	±0.1			ppb	See chart below
Vs. supply voltage		Ref V _{cc} typ.	±0.1			ppb	
Power Supply							
Voltage	V _{CC}		4.75	5.0	5.25	V	3.3, 12V supply available
Power Consumption		Warm-up state Steady state, +25°C		5 1.25	1.5	W W	
Warm-up time	t _{up}	to Δf/f = 1e-8 at +25°C			5	min	Ref to frequency after 30 min
SSB Phase Noise		1 Hz		-100		dBc/Hz	For 10 MHz operational frequency
		10 Hz		-130			
		100 Hz		-147			
		1 kHz		-155			
		10 kHz		-165			
Allan variance		1s	1			e-12	
Aging	Per day	After 30 days of operation	±0.1			ppb	See chart below
	First year		±15			ppb	
	For 10 years		±0.3			ppm	



Environmental, mechanical conditions.

Operating temperature range	See chart below
Storage temperature range	-60°C to +90°C
Humidity	Hermetically sealed
Mechanical Shock	Per MIL-STD-202, 30G half sine pulse, 11ms
Vibration	Per MIL-STD-202, 5G swept sine 10 to 500Hz
Soldering Conditions	Hand solder only – not reflow compatible 260°C 10s (on pins)
Washing Conditions	Washing with water or alcohol based detergent allowed only with final enough drying stage

* No frequency control option – on customer requirement

Ordering Code

DOCXO3627C	-	2	3	4	1	1	-	10 MHz
		1	2	3	4	5		

For example, DOCXO3627C-23411-10MHz denotes the OCXO has the following specifications:

Temperature Range	-10°C to +60°C
Stability Over Temperature	±2e ⁻¹⁰
Aging per day / year	0.5ppb / 0.005 ppm
Supply Voltage	5V ±5%
Output	HCMOS
Frequency	10MHz

1	Temperature Range
Code	Specification
1	0°C..+50°C
2	-10°C..+60°C
3	0°C..+70°C
4	-20°C..+70°C
5	-30°C..+70°C
6	-40°C..+85°C

2	Stability Over Temperature	
Code	Specification	Available temperature range code
1	±5e-11	1, 2, 3, 4, 5
2	±1e-10	1, 2, 3, 4, 5, 6
3	±2e-10	1, 2, 3, 4, 5, 6
4	±3e-10	1, 2, 3, 4, 5, 6
5	±5e-10	1, 2, 3, 4, 5, 6
6	±1e-9	1, 2, 3, 4, 5, 6

3	Aging per day/year, ppb/ppm
Code	Specification
1	0.1/0.015
2	0.2/0.020
3	0.3/0.030
4	0.5/0.005
5	1.0/0.100
6	1.5/0.150
7	2.0/0.200
8	3.0/0.300

4	Supply voltage
Code	Specification
1	+5V ±5%
2	+12V ±10%
3	+3.3V ±5%

5	Output
Code	Specification
1	HCMOS
2	Sine wave + 6 dBm min

*for 10 MHz operational frequency

Deviations of the parameters may be possible on Customer's requirements
Please contact Dynamic Engineers Inc. for further details.