



Features and Benefits

- High frequency stability (up to ±5 ppb over -30°C to +70°C)
- Low phase noise (up to -170 dBc/Hz @ 100 KHz)
- Low long term aging (up to ±2 ppb per day)
- Low power consumption (up to 100 mA steady state @ +25°C)
- Compact SMD design

Typical Applications

- SATCOM System
- Portable Microwave Applications

Description

OCXO2522LULN1-100MHz offers high frequency stability, low phase noise, low long term aging and power consumption, with wide range of frequency stability vs. operating temperature options, all in a compact SMD package to suit the different communication needs.

Mechanical Drawing & Pin Connections

Drawing No: MD140068-1

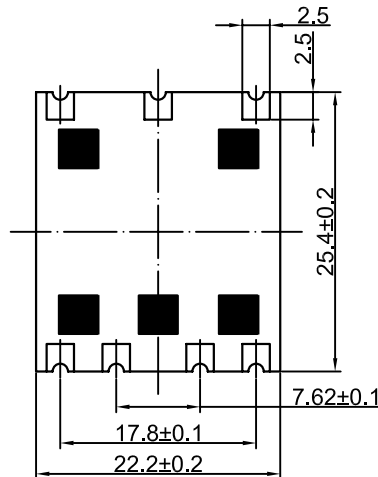

No pcbtrack beneath this area

Pin connections

Pin#	Symbol	Function
1	Vc	Control Voltage (EFC)
2	VREF	Reference Voltage
3	Vs	Supply Voltage
4	RF OUT	RF Output
5	N.C.	No Connection
6	N.C.	No Connection
7	GND	Ground

Unit in mm
1mm = 0.0394 inches

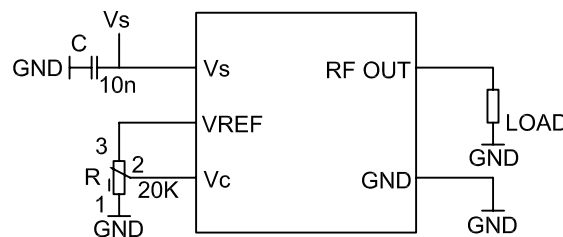
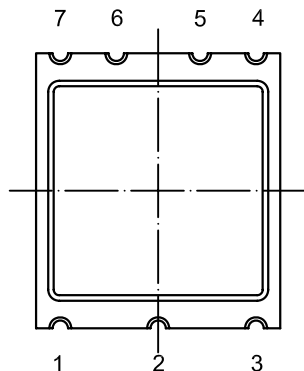



Specifications

Oscillator Specification	Sym	Condition	Value			Unit	Note
			Min.	Typ.	Max.		
Nominal Frequency	F_{nom}			100		MHz	
RF Output							
Signal Waveform			Sine wave				
Load	R_L	$\pm 5\%$	50			Ω	
Output Level			+7			dBm	Note 2
Harmonics					-30	dBc	
Warm-up time		$\Delta f_{final} / f_0 < \pm 0.1$ ppm			3	min	
G-Sensitivity		Per axis			1.0	ppb/g	
Power Supply							
Reference Voltage VREF Output				10.0		V	Note 3
Supply Voltage	V_S		11.4	12.0	12.6	V	Note 3
Current Consumption		Steady state, +25°C			100	mA	Note 4
		Warm-up			300	mA	Note 4
Frequency Adjustment Range							
Electronic Frequency Control (EFC)			± 1	± 2		ppm	
EFC voltage	V_c		0		VREF	V	
EFC Slope	$\Delta f / \Delta V_c$		positive				
EFC Input Impedance			100			k Ω	
Frequency Stability							
Versus Operating Temperature Range		Steady state	Refer to ordering options				
Initial Tolerance @+25°C		$V_c @ VREF / 2$		± 100	± 200	ppb	
Versus supply voltage variation (pushing)	V_S	$\pm 5\%$			± 10	ppb	
Versus load change (pulling)	R_L	$\pm 5\%$			± 5	ppb	
Long Term Aging Per Day		After 30 days operation			± 2	ppb	
Long Term Aging 1 st Year		After 30 days operation			± 200	ppb	
Phase noise @ 100 MHz			Refer to ordering table				
Environmental Conditions							
Operating temperature range	Refer to ordering options						
Storage temperature range	-55°C to +125°C						
Enclosure (see drawing) L x W x H	25.6 x 22.2 x 14.0 mm max. IEC 60679-3 CO 28 Note 5						
Weight	10 g max						

1. Terminology and test conditions are according to IEC60679-1 and MIL-PRF-55310, unless otherwise stated
2. Other output level available on request
3. Other supply and reference voltage available on request
4. May be higher for wide operating temperature range
5. Lower height H available on request

Absolute Maximum Ratings

Parameter	Sym	Min.	Max.	Unit	Condition
Supply Voltage	V_S	-0.5	$V_S + 10\%$	V	V_S to GND
Control Voltage	V_c	-0.5	15	V	V_c to GND

Handling and Testing

Parameter	Procedure		Condition
Electrostatic Discharge (ESD) THD Devices	IEC60749-26	HBM	2000V
	IEC60749-27	MM	200V
SMD Devices			
Washable	Yes		
RoHS-Compliant	Yes		



Ordering Options: Frequency vs. Operating Temperature

Frequency Stability		Temperature (Lower)		Temperature (Upper)	
Code	Stability [ppb]	Code	T (°C)	Code	T (°C)
1	±5	1	0	1	+50
2	±10	2	-10	2	+60
3	±25	3	-20	3	+70
4	±50	4	-30	4	+75
5	±100	5	-40	5	+80
6	±200	6	-55	6	+85

Ordering Options Availability

Frequency Stability	Temperature Range (°C)						
	0 ~ +50	-10 ~ +60	-20 ~ +70	-30 ~ +70	-40 ~ 75	-40 ~ +85	-55 ~ +85
1	On Request	On Request	On Request	On Request	Not available	Not available	Not available
2	Available	Available	Available	On Request	On Request	Not available	Not available
3	Available	Available	Available	Available	Available	On Request	On Request
4	Available	Available	Available	Available	Available	Available	Available
5	Available	Available	Available	Available	Available	Available	Available
6	Available	Available	Available	Available	Available	Available	Available

Ordering Options: Phase Noise

Offset	10 Hz	100 Hz	1 KHz	10 KHz	≥ 100 KHz
Code	Phase Noise dBc / Hz				
A	-90	-125	-150	-160	-170
B	-95	-130	-153	-160	-170
C	-97	-132	-155	-160	-170
D	-100	-135	-157	-163	-170
E	-105	-137	-158	-165	-170

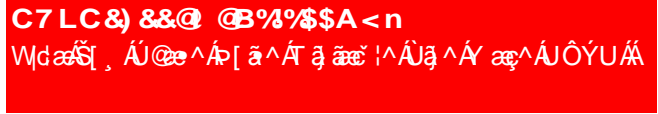

Ordering Codes

Model	Frequency Stability	Minimum Operating Temperature	Maximum Operating Temperature	Phase Noise Performance Level
OCXO2522LULN1-100MHz	t	w	Z	pn

Example: OCXO22522LULN1-100-3-5-6-A has the following specifications

Stability = ±25 ppb
 Operating Temperature = -40°C to +85°C
 Phase Noise

Offset	Phase Noise dBc / Hz
10 Hz	-90
100 Hz	-125
1 KHz	-150
10 KHz	-160
≥ 100 KHz	-170

***Note: Not all combinations of stability and operating temperature limits are available. Please consult DEI for further details.

Environmental Conditions

Test	IEC 60068 Part...	IEC 60679-1 Clause	MIL-STD-202G Method	MIL-STD-810F Method	MIL-PRF-55310D Clause	Test Conditions (IEC)
Sealing tests (if applicable)	2-17	5.6.2	112E		3.6.1.2	Gross leak: Test Qc, Fine leak: Test Qk
Solderability Resistance to soldering heat	2-20 2-58	5.6.3	208H 210F		3.6.52 3.6.48	Test Ta Method 1 Test Td ₁ Method 2 Test Td ₂ Method 2
Shock	2-27	5.6.8	213B	516.4	3.6.40	Test Ea, 3 x per axes 100g, 6 ms half-sine pulse
Vibration sinusoidal	2-6	5.6.7.1	201A 204D	516.4-4	3.6.38.1 3.6.38.2	Test Fc, 30 min per axes, 10 Hz – 55 Hz 0,75mm; 55 Hz – 2 kHz, 10g
Vibration, random	2-64	5.6.7.3	214A	514.5	3.6.38.3 3.6.38.4	Test Fdb
Endurance tests - aging - extended aging		5.7.1 5.7.2	108A		4.8.35	30 days @+85°C, OCXO @ +25°C 1000h, 2000h, 8000h @ +85°C