



Features and Benefits

Very low phase noise up to -175 dBc/Hz, floor
High temperature stability up to ±1 ppb at -40°C to +85°C
Low aging up to ±0.2 ppb/day, 20 ppb/year
Compact packaging
Frequency range from 5 MHz to 150 MHz

Typical Applications

Stratum 3E clock systems
Cellular Base Station
Microwave Communications
Radar Reference
Instrumentation

Description

A new series of low phase-noise OCXO with high temperature stability for optimal performance.

Mechanical Drawing & Pin Connections

Drawing No:MD140078-1

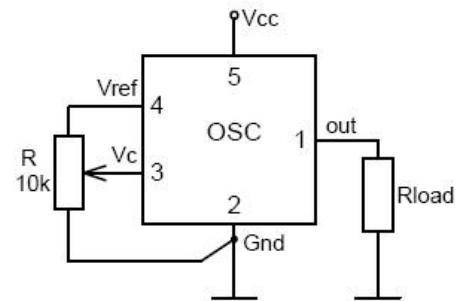
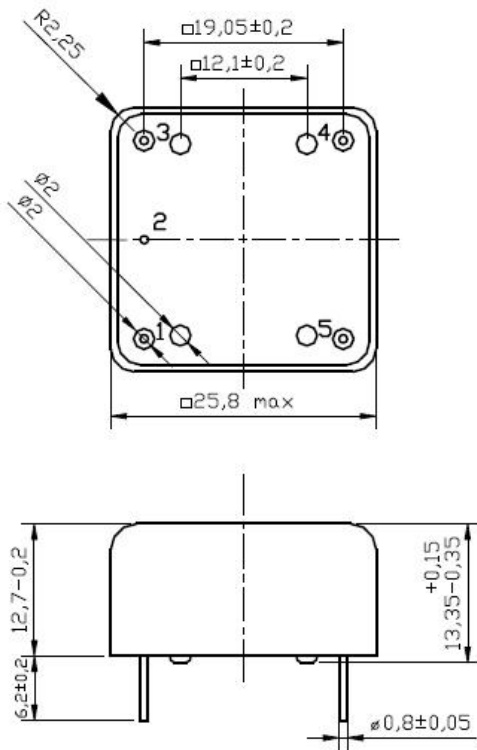

Pin	Signal
1	RF Out
2	GND
3	Electrical tuning
4	Reference voltage
5	+V Supply

* - 10.7 mm height is available



Specifications

General Specifications								
Parameter	Sym	Condition	Value			Unit	Note	
			Min.	Typ.	Max			
Frequency Range	F ₀		5		150	MHz	Fundamental operation	
RF Output								
HCMOS (TTL) option	Load		10		15	kOhm pF	For 10 MHz operational frequency	
	H-level voltage	V _H	V _{cc} =5V or 12V V _{cc} =3.3V	3.8 2.4		V		
	L-level voltage	V _L			0.4	V		
	Duty Cycle			45		55	%	
	Rise / Fall Time					10	ns	For 10 MHz operational frequency
Sine-wave option	Level	L		+6	+8	+10	dBm	
	Load	R _L			50		Ohm	
	Harmonics level					-30	dBc	
Spurious level						-100	dBc	
Frequency Control*								
Control Voltage Range	V _c	V _{cc} =5V or 12V V _{cc} =3.3V	0 0		4.2 2.8	V	Positive tuning slope – (standard option)	
Tuning Range			±0.5	±1		ppm		
Reference voltage	V _{ref}	V _{cc} =5V or 12V V _{cc} =3.3V	4.1 2.7	4.2 2.8	4.3 2.9	V		
Frequency Stability								
Vs. temperature		-40°C to +85°C, ref 25°C		±10		ppb	See chart below	
Vs. supply voltage		Ref V _{cc} typ.		±1		ppb		
Vs. acceleration		Worst direction	±0.5		±1	ppb/G		
Power Supply								
Voltage	V _{CC}		4.75	5.0	5.25	V	3.3V, 12V optional	
Power Consumption		Warm-up state Steady state, +25°C		3.2 1	3.5 1.2	W W		
Warm-up time	t _{up}	to Δf/f = 1e-7, at +25°C			180	Sec	Ref to frequency after 30 min	
SSB Phase Noise		1 Hz	-106/-	-100/-		dBc/Hz	For 10 MHz /100 MHz operational frequency	
		10 Hz	-135/-95	-125/-90				
		100 Hz	-155/-130	-145/-120				
		1 kHz	-163/-155	-155/-150				
		10 kHz	-170/-170	-165/-165				
		100 kHz	-172/-175	-168/-168				
Allan variance		1s	5	10		e-12		
Aging	Per day	After 30 days of operation	0.2	0.5		ppb	For 10 MHz See chart below	
	First year		20	50		ppb		
	For 20 years		0.3	0.5		ppm		



Environmental, mechanical conditions.	
Operating temperature range	See chart below
Storage temperature range	-60°C to +90°C
Humidity	Hermetically sealed
Mechanical Shock	Per MIL-STD-202, 30G half sine pulse, 11ms
Vibration	Per MIL-STD-202, 10G swept sine 10 to 2000Hz
Soldering Conditions	Hand solder only – not reflow compatible 260°C 10s (on pins)
Washing Conditions	Washing with water or alcohol based detergent allowed only with final enough drying stage

* No frequency control option – on customer requirement

Ordering Code

OCXO2525C_Rev2	-	2	6	4	2	1	-	10 MHz
Group		1	2	3	4	5		

For example, OCXO2525C_Rev2-26421-10MHz denotes the OCXO has the following specifications:

Temperature Range	-10°C to +60°C
Stability Over Temperature	±10ppb
Aging per day / year	1.0ppb / 0.10 ppm
Supply Voltage	3.3V ±10%
Output	HCMOS/TTL
Frequency	10MHz

1	Temperature Range
Code	Specification
1	0°C..+50°C
2	-10°C..+60°C
3	0°C..+70°C
4	-20°C..+70°C
5	-30°C..+70°C
6	-40°C..+85°C
7	-55°C..+85°C
8	-40°C..+125°C

2	Stability Over Temperature		
Code	Specification	Available temperature range code	
		For 10 MHz	For 100 MHz
1	±0.5 ppb	1, 2	-
2	±1.0 ppb	1, 2, 3, 4, 5, 6	-
3	±2.0 ppb	1, 2, 3, 4, 5, 6	-
4	±3.0 ppb	1, 2, 3, 4, 5, 6, 7	1
5	±5.0 ppb	1, 2, 3, 4, 5, 6, 7	1, 2, 3, 4, 5, 6
6	±10.0 ppb	1, 2, 3, 4, 5, 6, 7	1, 2, 3, 4, 5, 6, 7
7	±20.0 ppb	1, 2, 3, 4, 5, 6, 7, 8	1, 2, 3, 4, 5, 6, 7
8	±50.0 ppb	1, 2, 3, 4, 5, 6, 7, 8	1, 2, 3, 4, 5, 6, 7
9	±100.0 ppb	1, 2, 3, 4, 5, 6, 7, 8	1, 2, 3, 4, 5, 6, 7

3	Aging per day/year, ppb/ppm	
Code	Specification	
1	0.2/0.02	≤10MHz
2	0.3/0.03	
3	0.5/0.05	≤20MHz
4	1.0/0.10	≤40MHz
5	1.5/0.15	≤50MHz
6	2.0/0.20	≤120MHz
7	3.0/0.30	
8	5.0/0.50	≤150MHz

4	Supply voltage
Code	Specification
1	5V ±5%
2	3.3V ±5%
3	12V ±10%

5	Output
Code	Specification
1	HCMOS/TTL
2	Sine wave

Disclaimer: Not all option choices available across entire frequency range
 Please contact Dynamic Engineers Inc. for further details.